



Technical Service BULLETIN

November 8, 2007

Title:

FRONT AND REAR DIFFERENTIAL GEAR OIL SPECIFICATION CHANGE

Models:

'03 – '08 4Runner & '07 – '08 FJ Cruiser

DRIVELINE & DIFFERENTIAL
DL003-07

Introduction The differential gear oil used in 4Runner and FJ Cruiser vehicles has been changed to a 75W-85 GL5 synthetic gear oil beginning with the 2008 model year. This new synthetic gear oil is compatible with 2003 – 2007 model year 4Runner and 2007 model year FJ Cruiser differentials. Please refer to the Parts Information section below for information about this gear oil and use this gear oil (or equivalent) when filling front or rear differentials with oil.

Applicable Vehicles

- 2003 – 2008 model year 4Runner vehicles.
- 2007 – 2008 model year FJ Cruiser vehicles.

Parts Information

PREVIOUS PART NUMBER	CURRENT PART NUMBER	PART NAME	TYPE	QTY
N/A	08885-02606	Toyota Genuine Differential Gear Oil LX 75W-85 API GL-5 SAE 75W-85	LSD	As Needed
N/A	08885-02506	Toyota Genuine Differential Gear Oil LT 75W-85 API GL-5 SAE 75W-85	w/o LSD	As Needed

Refer to the diagram below to identify if LSD or non-LSD gear oil is used on the vehicle. For applicable vehicles, there is a caution label above the filler plug, as shown below.

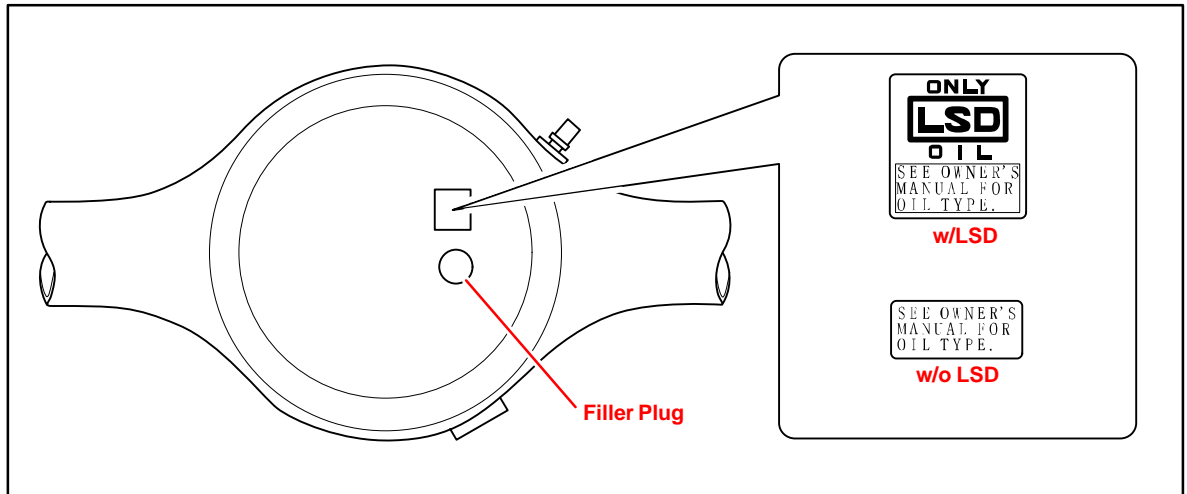

Warranty Information

OP CODE	DESCRIPTION	TIME	OFF	T1	T2
N/A	Not Applicable to Warranty	-	-	-	-

