

Turn Signal and Hazard Warning Light with DRL

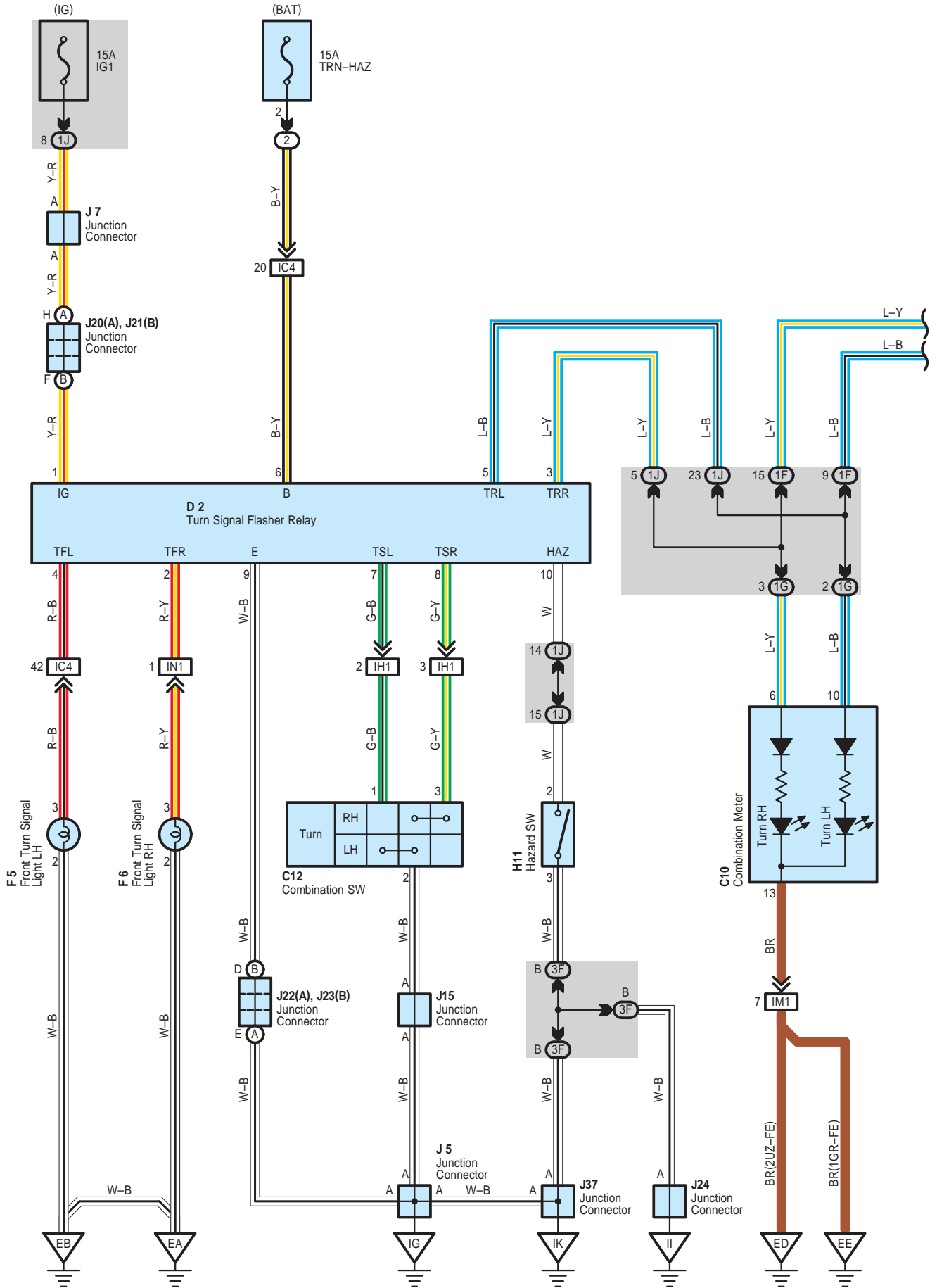

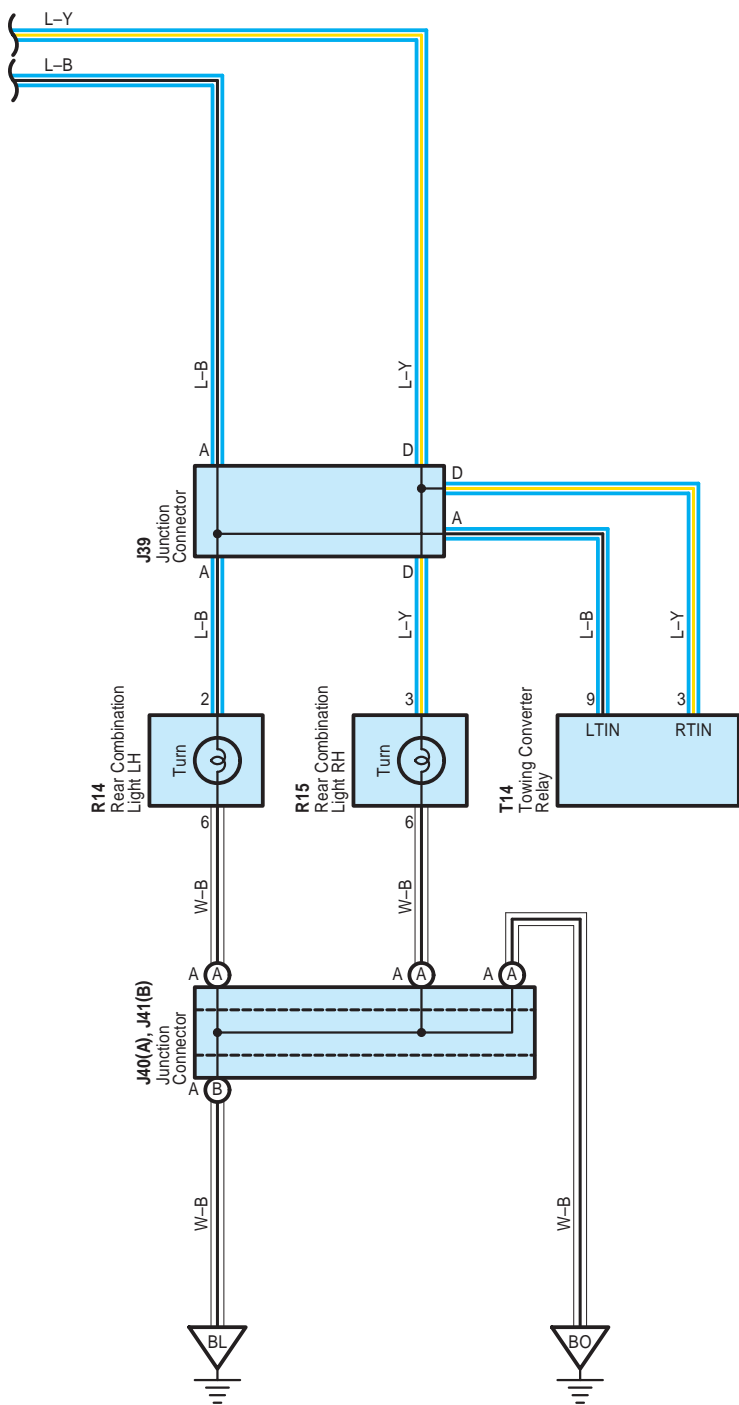

Turn Signal and Hazard Warning Light with DRL

: Parts Location

Code	See Page	Code	See Page	Code	See Page
C10	37	J5	38	J37	38
C12	37	J7	38	J39	40
D2	37	J15	38	J40	A 40
F5	32 (2UZ-FE)	J20	A 38	J41	B 40
	34 (1GR-FE)	J21	B 38	R14	41
F6	32 (2UZ-FE)	J22	A 38	R15	41
	34 (1GR-FE)	J23	B 38	T14	41
H11	37	J24	38		

: Relay Blocks

Code	See Page	Relay Blocks (Relay Block Location)
2	22	Engine Room R/B (Engine Compartment Left)

: Junction Block and Wire Harness Connector

Code	See Page	Junction Block and Wire Harness (Connector Location)
1F	24	Floor No.2 Wire and Driver Side J/B (Lower Finish Panel)
1G	25	Instrument Panel Wire and Driver Side J/B (Lower Finish Panel)
1J		
3F	28	Instrument Panel Wire and Center J/B (Instrument Panel Brace RH)

: Connector Joining Wire Harness and Wire Harness

Code	See Page	Joining Wire Harness and Wire Harness (Connector Location)
IC4	46	Instrument Panel Wire and Engine Room Main Wire (Left Kick Panel)
IH1	46	Instrument Panel Wire and Instrument Panel Wire (Behind the Combination Meter)
IM1	47	Engine Wire and Instrument Panel Wire (Right Side of Blower Unit)
IN1	47	Instrument Panel Wire and Engine Room Main Wire (Right Kick Panel)

: Ground Points

Code	See Page	Ground Points Location
EA	44 (2UZ-FE)	Front Right Fender
	45 (1GR-FE)	
EB	44 (2UZ-FE)	Front Left Fender
	45 (1GR-FE)	
ED	44 (2UZ-FE)	Left Bank Cylinder Head
EE	44 (2UZ-FE)	Rear Side of Cylinder Block
	45 (1GR-FE)	Rear Side of Right Bank Cylinder Block
IG	46	Left Kick Panel
II	46	Instrument Panel Brace RH
IK	46	Right Kick Panel
BL	48	Floor Seat Crossmember LH
BO	48	Rear Pillar LH

