

# F RELAY LOCATIONS

## [Engine Compartment]

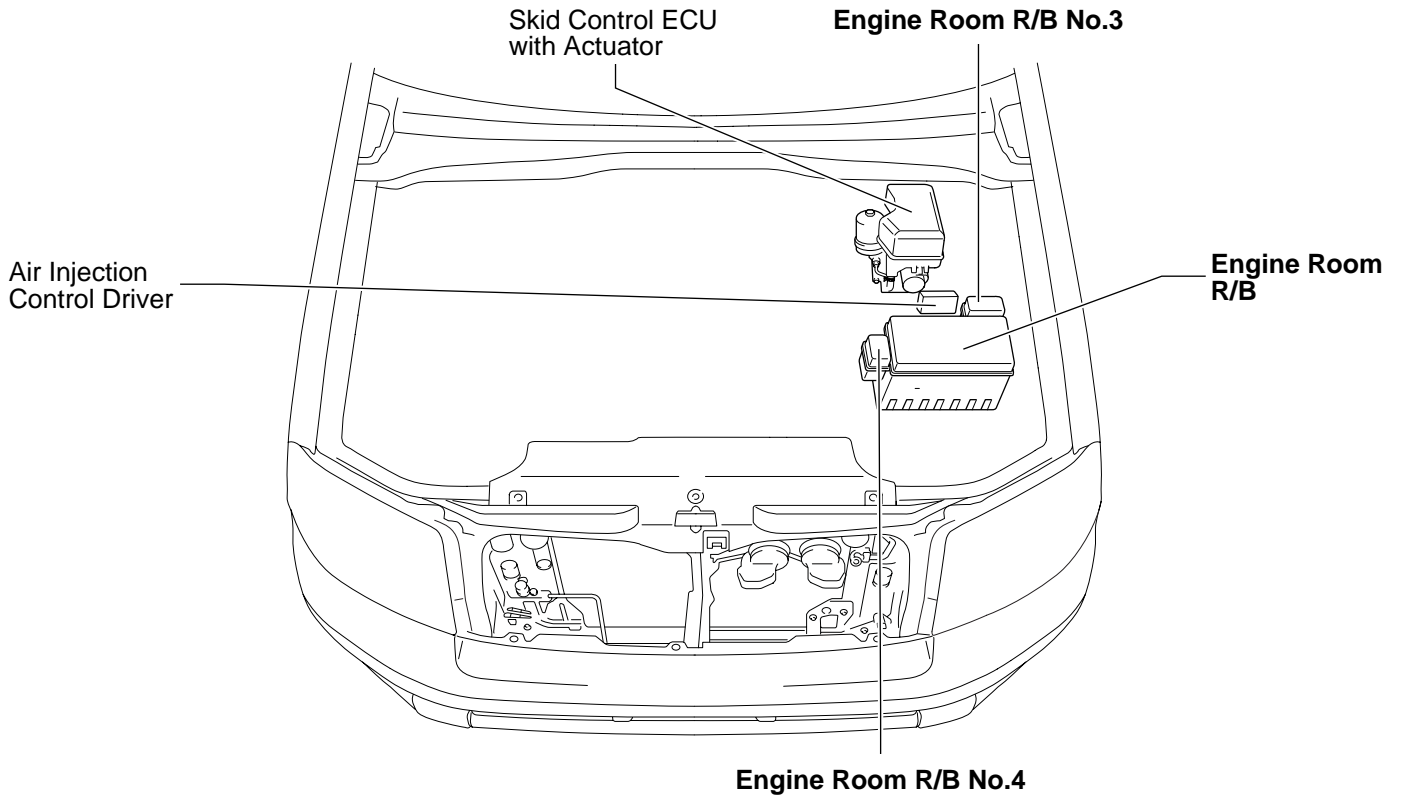

## [Body]

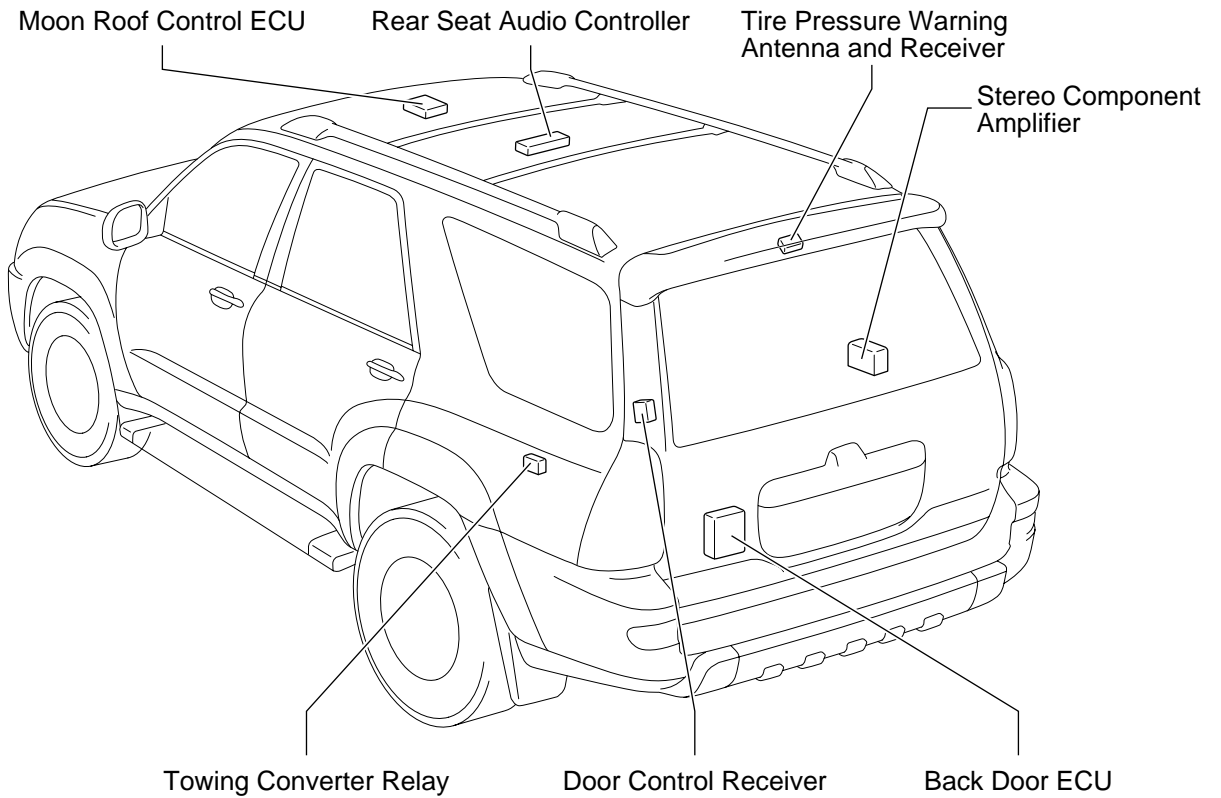

**[Instrument Panel]**

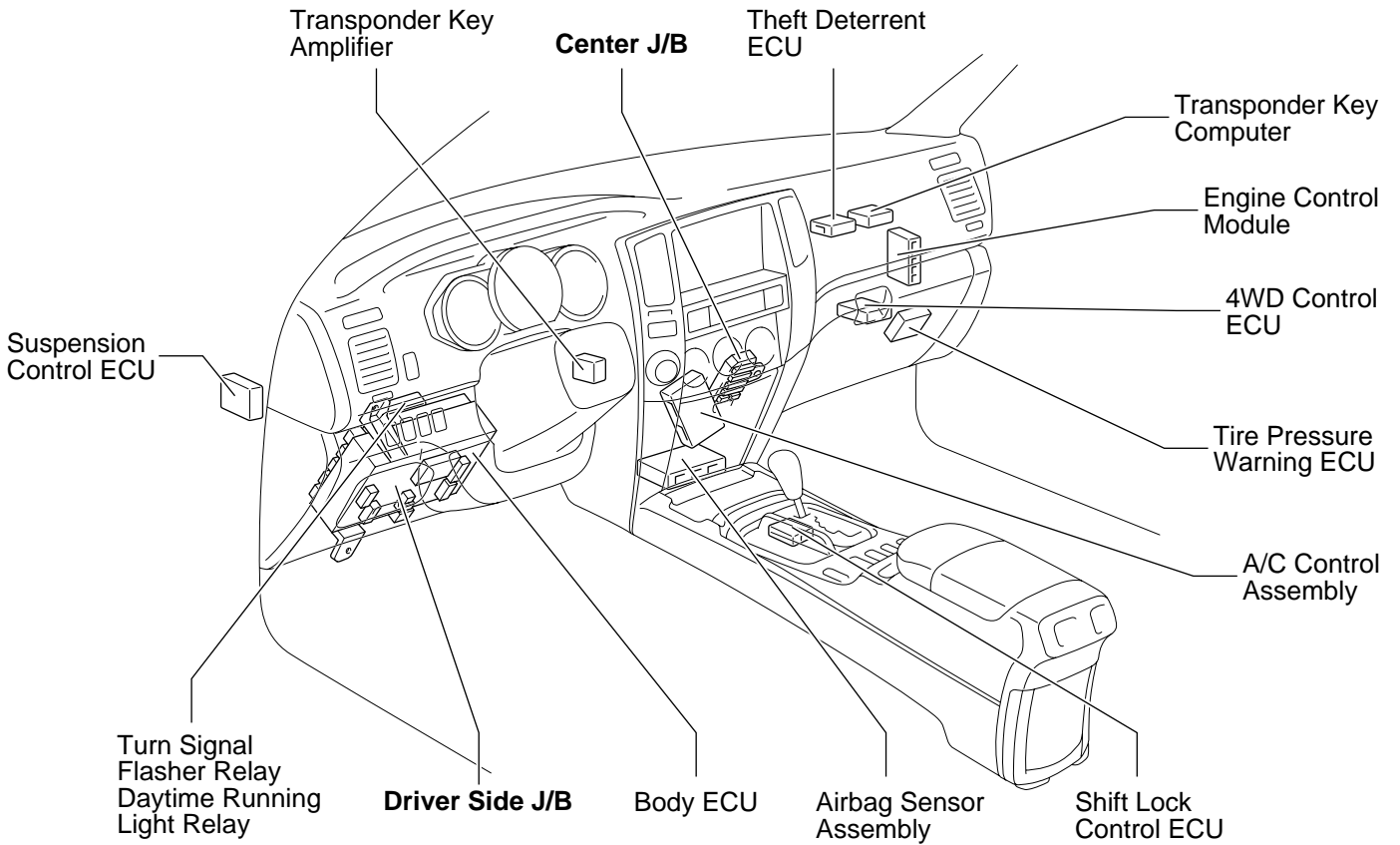

**[Seat]**

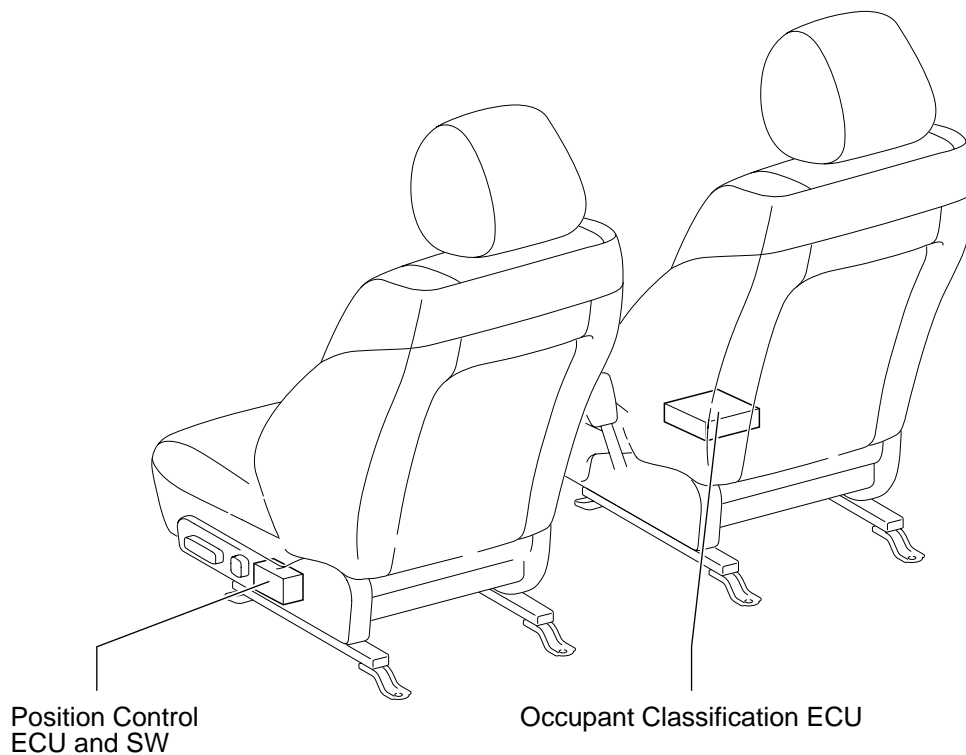

# F RELAY LOCATIONS

## ② : Engine Room R/B Engine Compartment Left (See Page 20)

- \* 1: ACC CUT Relay
- \* 2: FR FOG Relay
- \* 3: STA Relay
- \* 4: HEATER Relay
- \* 5: MG CLT Relay
- \* 6: RADIO NO.1
- \* 7: C/OPN Relay
- \* 8: DOME Relay
- \* 9: EFI Relay
- \* 10: A/F HEATER Relay
- \* 11: HEAD (LO LH)
- \* 12: HEAD (HI LH)

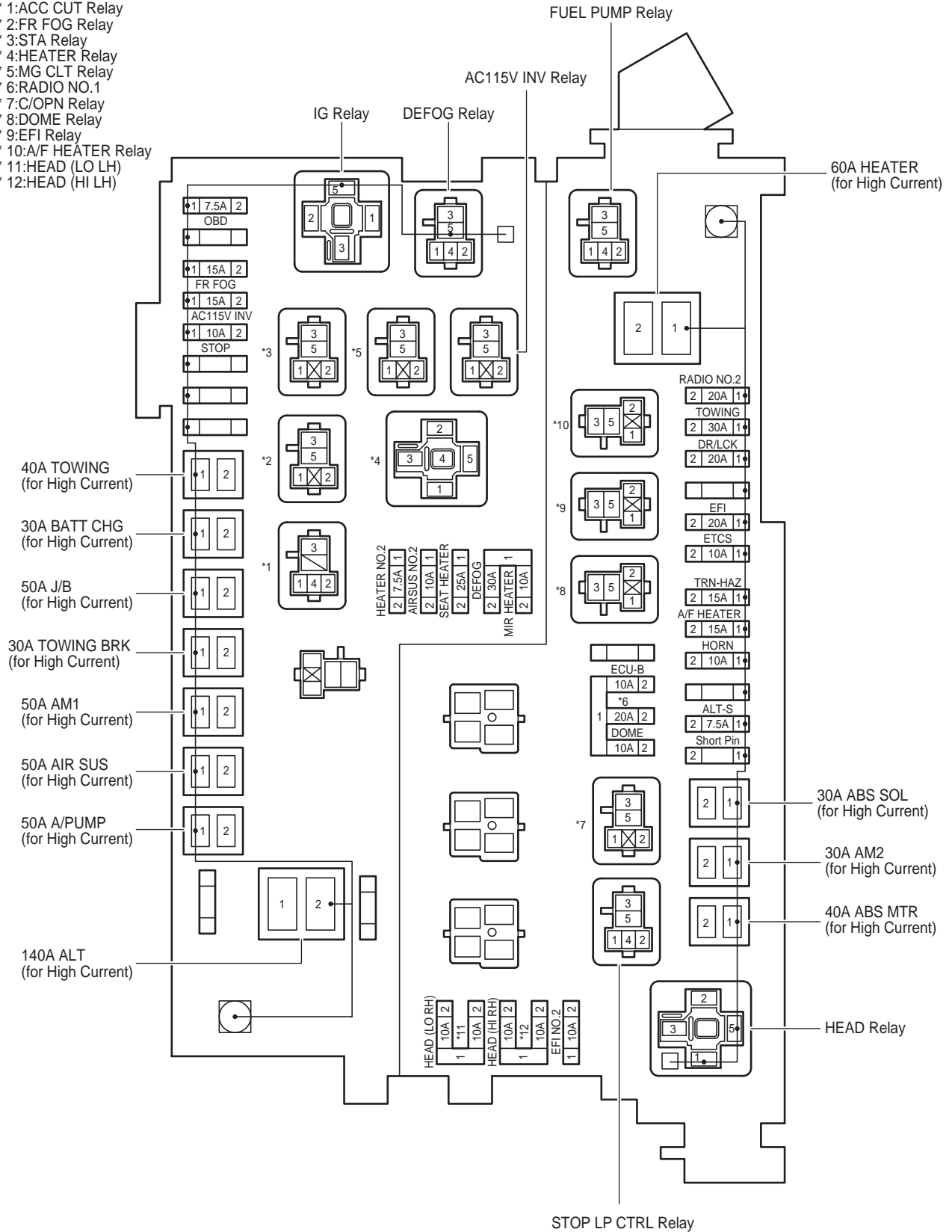

③ : Engine Room R/B No.3 Engine Compartment Left (See Page 20)

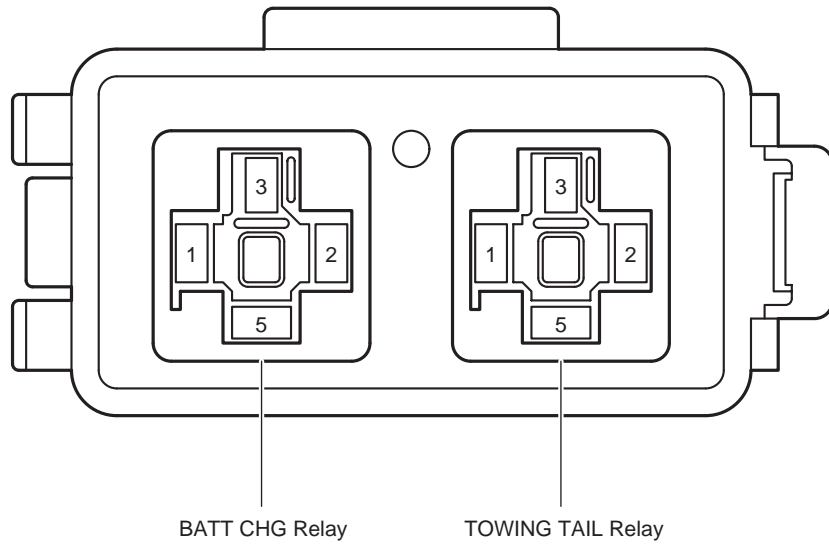

④ : Engine Room R/B No.4 Engine Compartment Left (See Page 20)

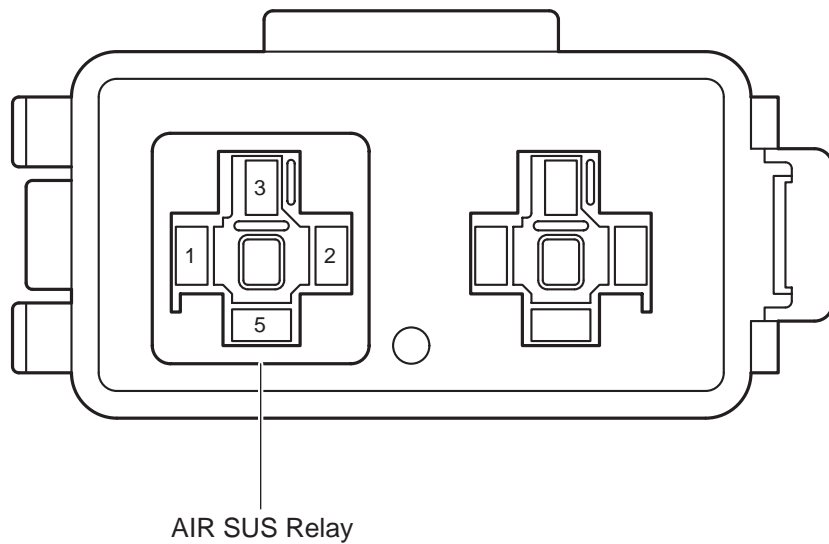

# F RELAY LOCATIONS

○ : Driver Side J/B      Lower Finish Panel (See Page 21)

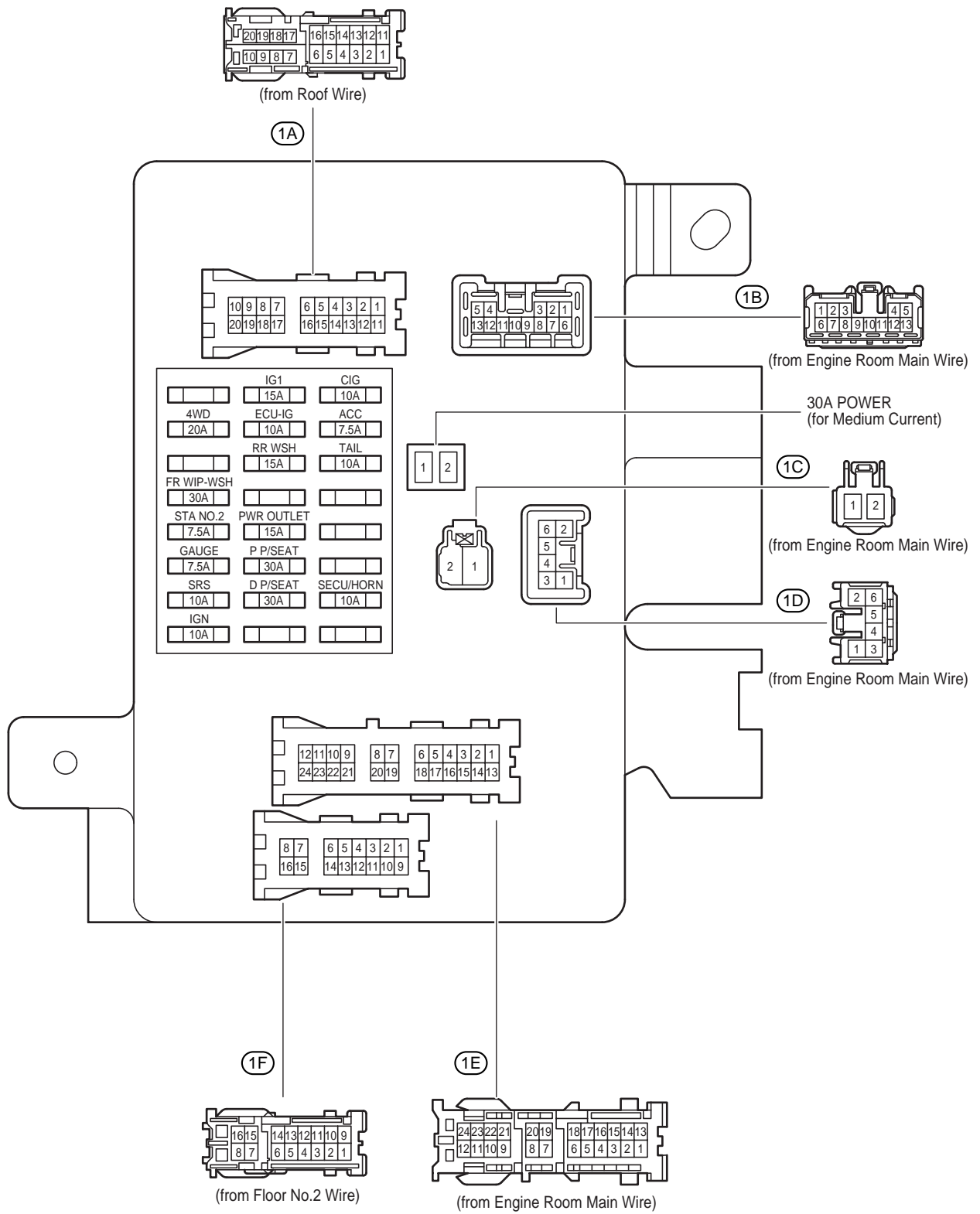

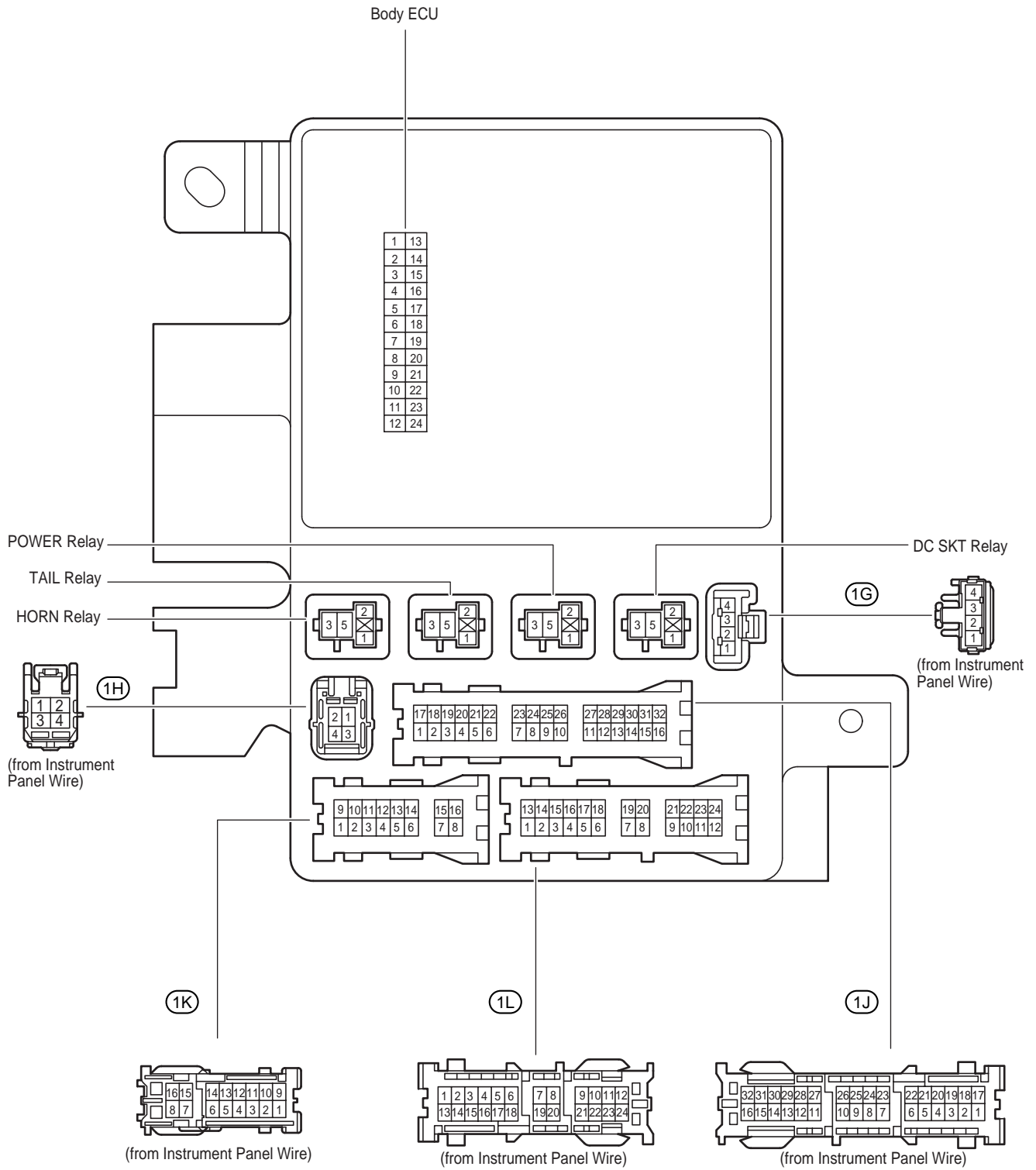

# F RELAY LOCATIONS

## [Driver Side J/B Inner Circuit]

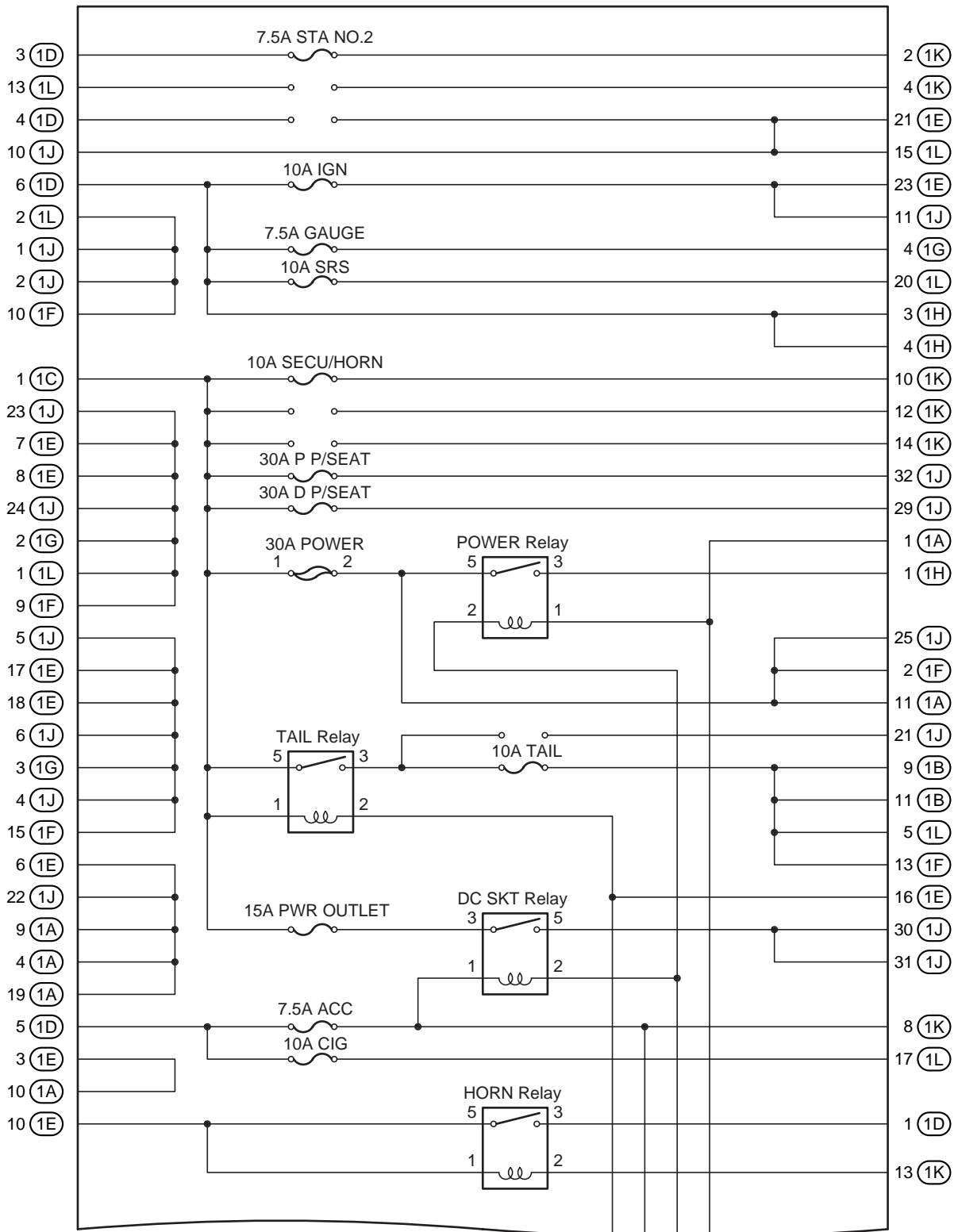

(Cont. Next Page)

(Cont'd)

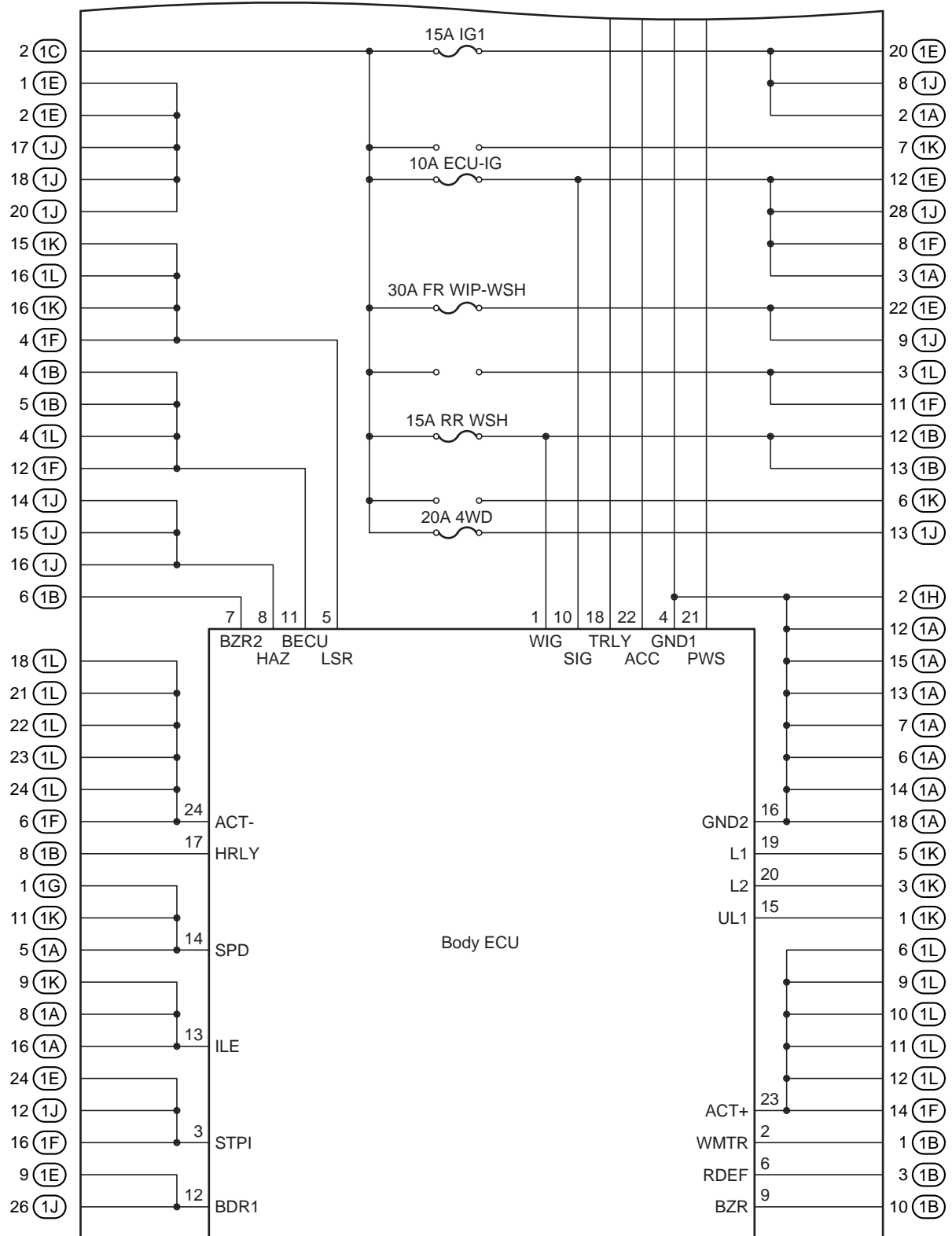



# F RELAY LOCATIONS

○ : Center J/B      Instrument Panel Brace RH (See Page 21)

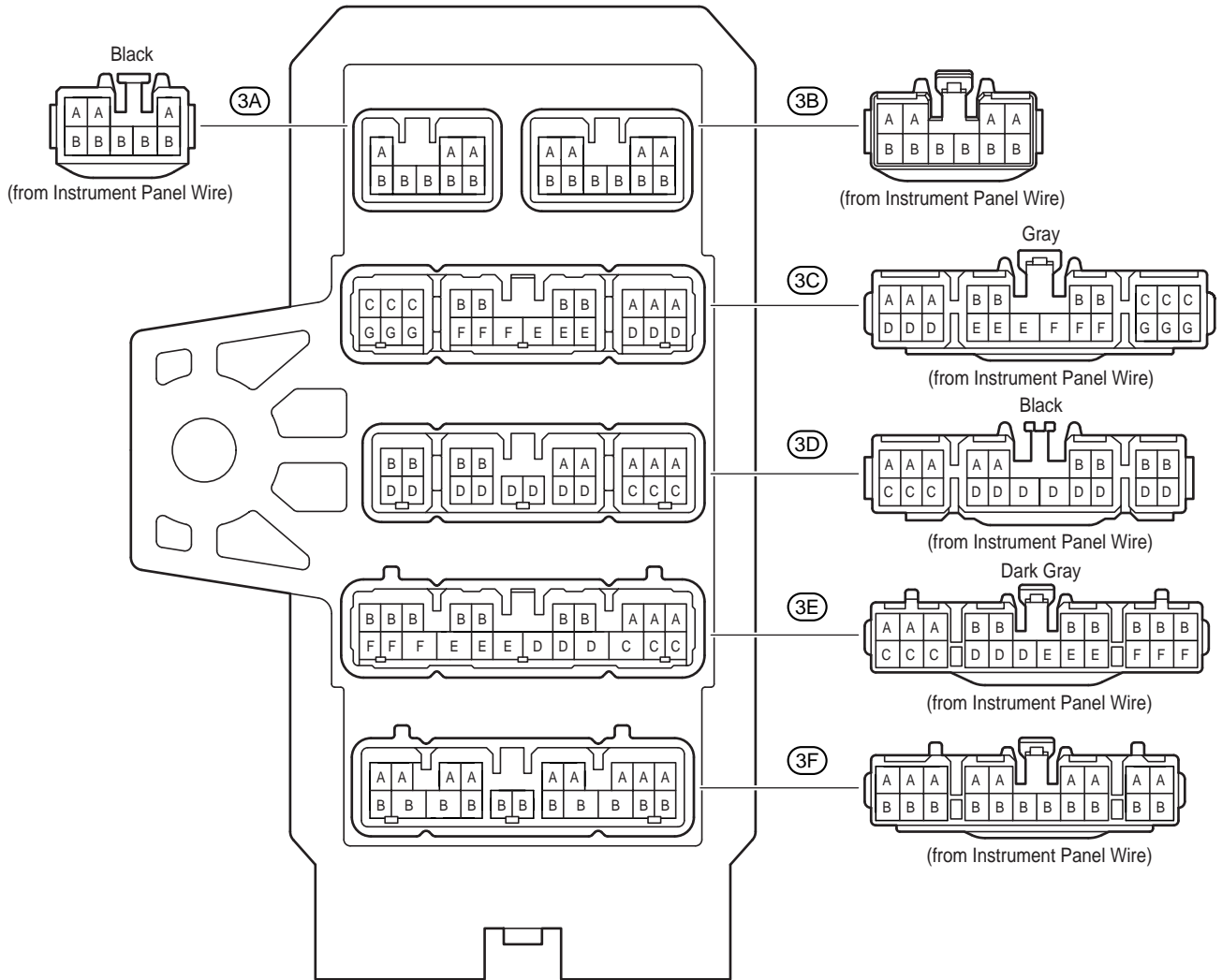



# F RELAY LOCATIONS

## [Center J/B Inner Circuit]

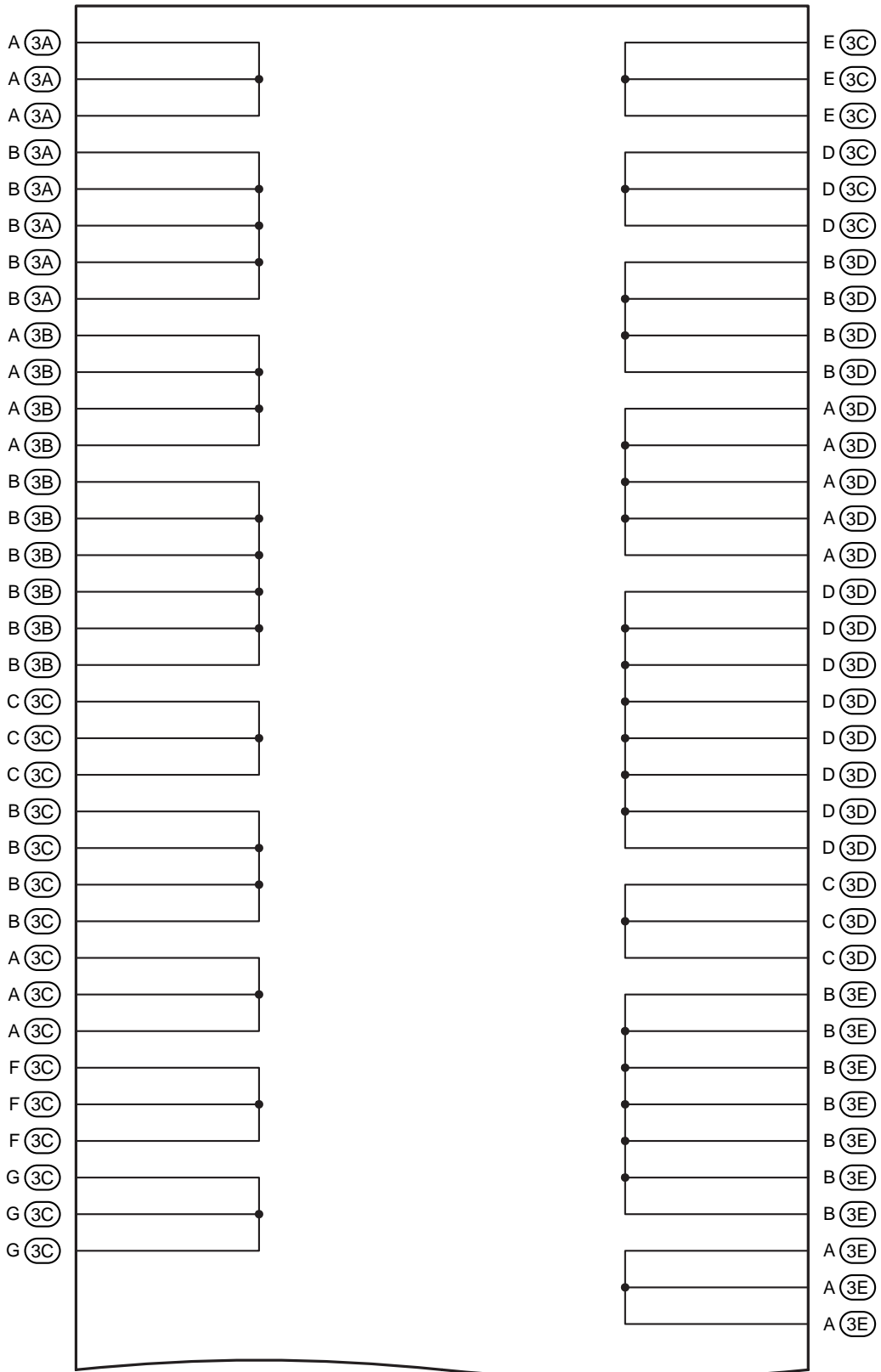

(Cont. Next Page)

(Cont'd)

