

Headlight

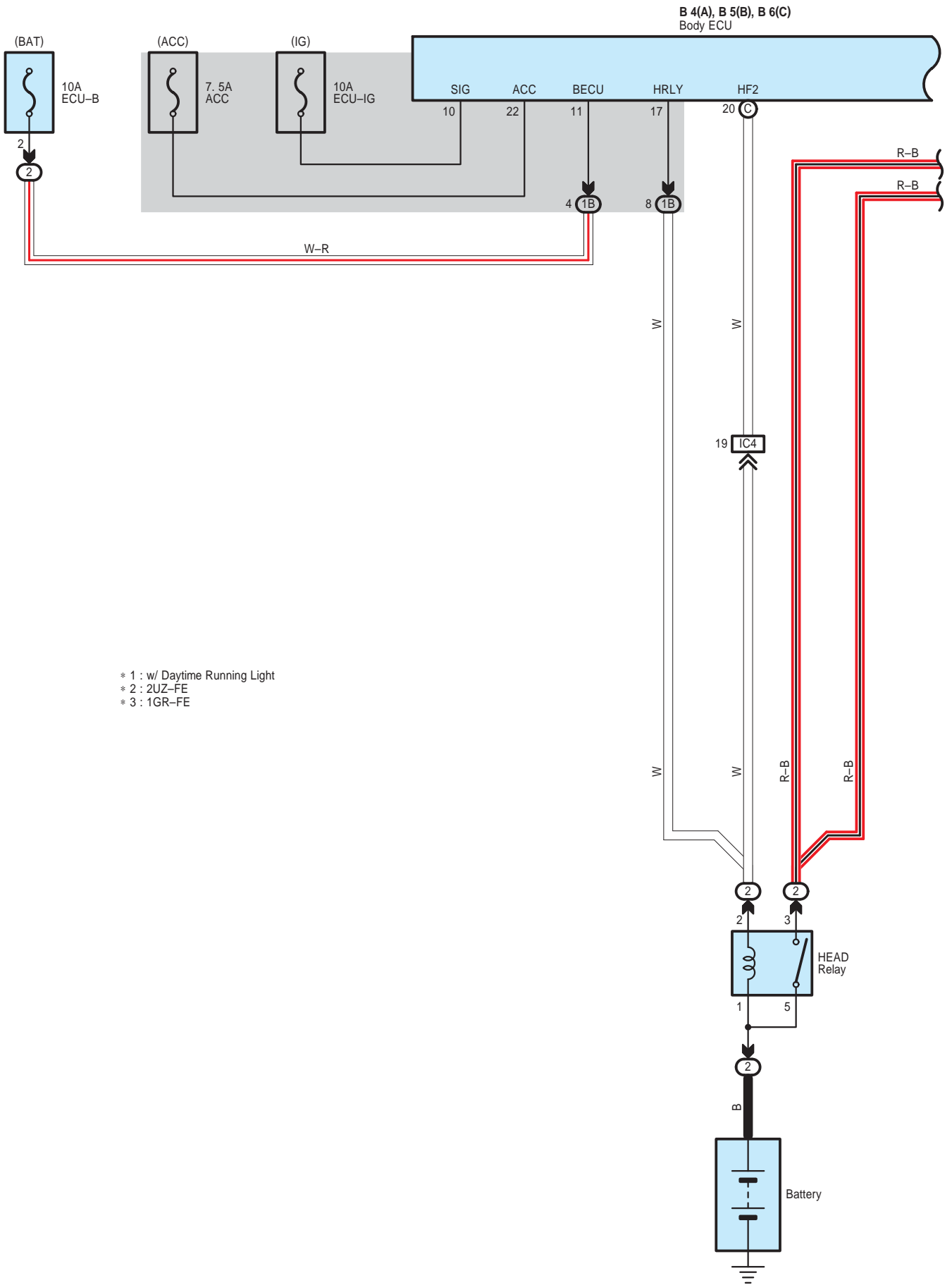

B 4(A), B 5(B), B 6(C)
Body ECU

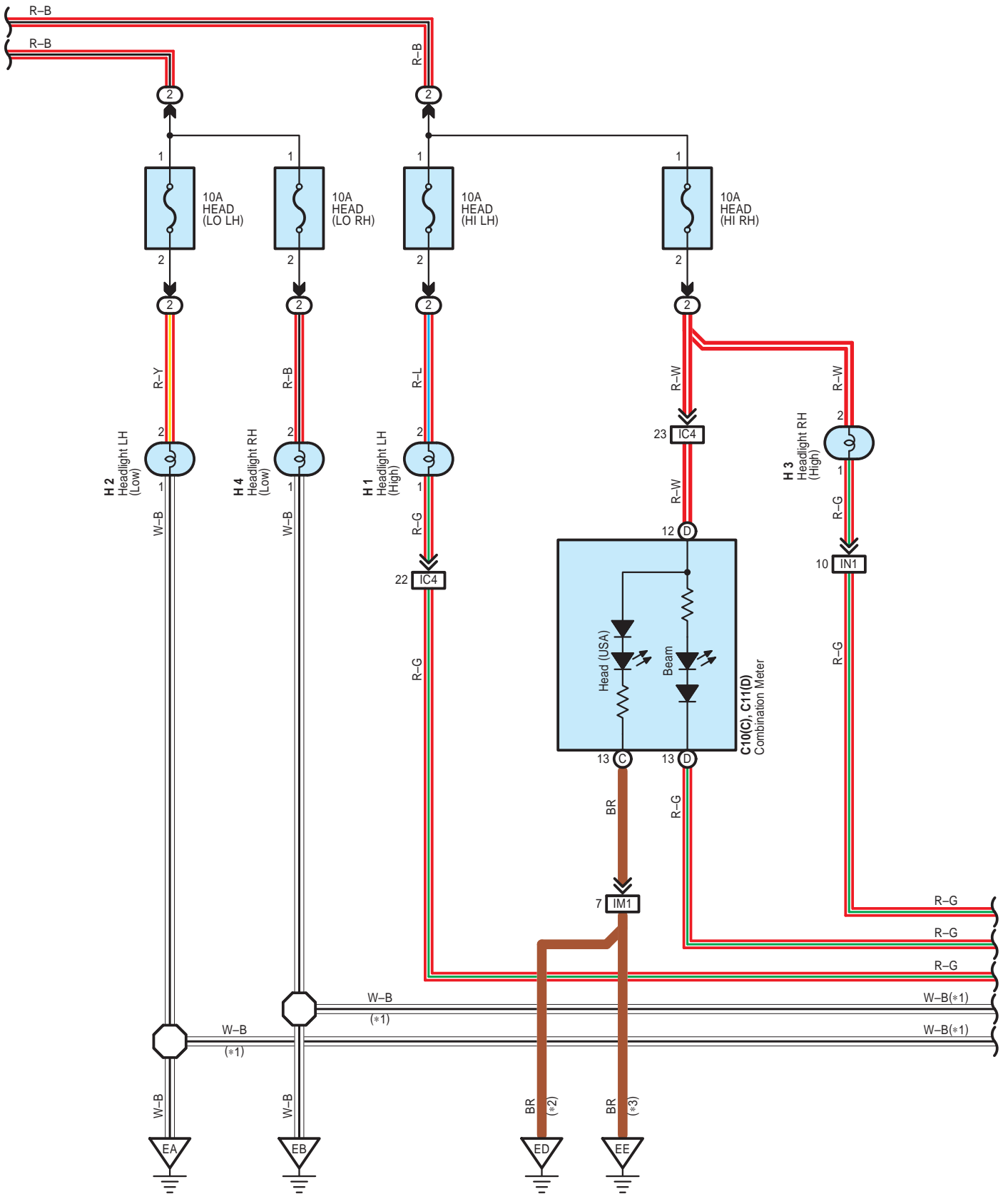

B 4(A), B 5(B), B 6(C)
Body ECU

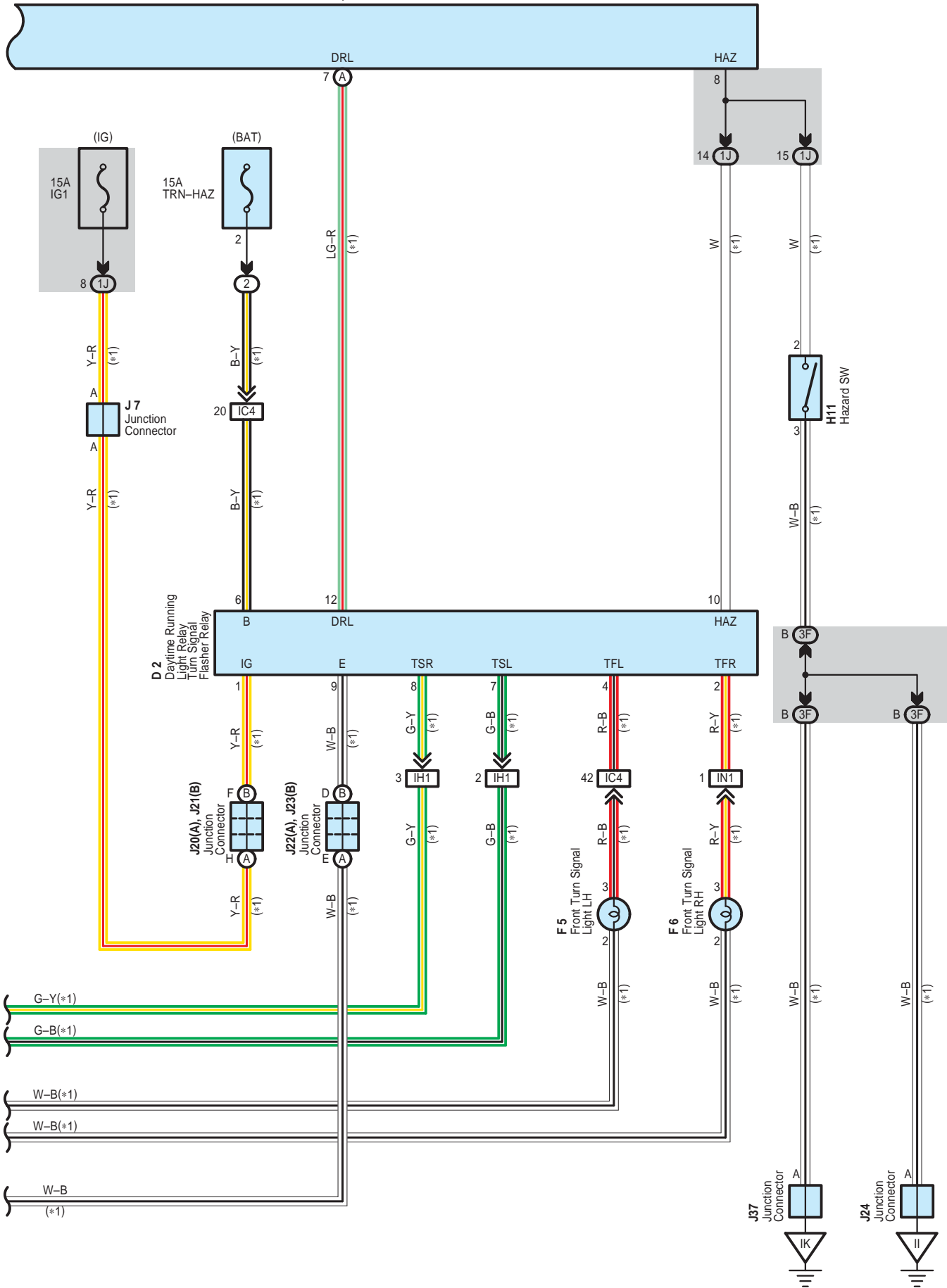

Headlight

System Outline

(w/ daytime running light)

* This system is designed to automatically activate the turn signal lights during the daytime to keep the car highly visible to other vehicles. This system is controlled by the body ECU.

This system makes use of the turn signal lights as daytime running lights.

For this reason, when the turn signal lights are operated, the daytime running lights function is interrupted momentarily, which, however, will be brought back into operation as soon as the interposed operation is over.

* This system is enabled when the conditions given below are met.

- A) Ignition switch ON condition
- B) Turn signal light switch OFF condition
- C) Hazard light switch OFF condition
- D) Light control switch OFF condition
- E) Parking brake switch OFF condition (Parking brake out of operating condition)**

** : This system does not become active when the parking brake switch is ON. However, once the OFF signal of the parking brake switch is input into the body ECU, this system will become active thereafter, regardless of whether the parking brake switch is ON or OFF.

○ : Parts Location

Code	See Page	Code	See Page	Code	See Page
B4	A 36	H1	32 (2UZ-FE)	J12	A 38
B5	B 36		34 (1GR-FE)	J13	B 38
B6	C 36	H2	32 (2UZ-FE)	J15 38	
C10	C 37		34 (1GR-FE)	J18	A 38
C11	D 37	H3	32 (2UZ-FE)	J19	B 38
C12	37		34 (1GR-FE)	J20	A 38
D2	37	H4	32 (2UZ-FE)	J21	B 38
F5	32 (2UZ-FE)		34 (1GR-FE)	J22	A 38
		34 (1GR-FE)	H11	37	J23
F6	32 (2UZ-FE)	J5	38	J24 38	
	34 (1GR-FE)	J7	38	J37 38	
G2	32 (2UZ-FE)	J10	A 38	P4 39	
	34 (1GR-FE)	J11	B 38		

○ : Relay Blocks

Code	See Page	Relay Blocks (Relay Block Location)
2	22	Engine Room R/B (Engine Compartment Left)

○ : Junction Block and Wire Harness Connector

Code	See Page	Junction Block and Wire Harness (Connector Location)
1B	24	Engine Room Main Wire and Driver Side J/B (Lower Finish Panel)
1E		
1H	25	Instrument Panel Wire and Driver Side J/B (Lower Finish Panel)
1J		
3F	28	Instrument Panel Wire and Center J/B (Instrument Panel Brace RH)

□ : Connector Joining Wire Harness and Wire Harness

Code	See Page	Joining Wire Harness and Wire Harness (Connector Location)
EA1	44 (2UZ-FE)	Engine No.2 Wire and Engine Room Main Wire (Under the Engine Room R/B)
EA2	45 (1GR-FE)	
IC4	46	Instrument Panel Wire and Engine Room Main Wire (Left Kick Panel)
IH1	46	Instrument Panel Wire and Instrument Panel Wire (Behind the Combination Meter)
IM1	47	Engine Wire and Instrument Panel Wire (Right Side of Blower Unit)
IN1	47	Instrument Panel Wire and Engine Room Main Wire (Right Kick Panel)



: Ground Points

Code	See Page	Ground Points Location
EA	44 (2UZ-FE)	Front Right Fender
	45 (1GR-FE)	
EB	44 (2UZ-FE)	Front Left Fender
	45 (1GR-FE)	
ED	44 (2UZ-FE)	Left Bank Cylinder Head
EE	44 (2UZ-FE)	Rear Side of Cylinder Block
	45 (1GR-FE)	Rear Side of Right Bank Cylinder Block
IG	46	Left Kick Panel
II	46	Instrument Panel Brace RH
IK	46	Right Kick Panel